

# Vent-Axia®

# Uniflex plus +

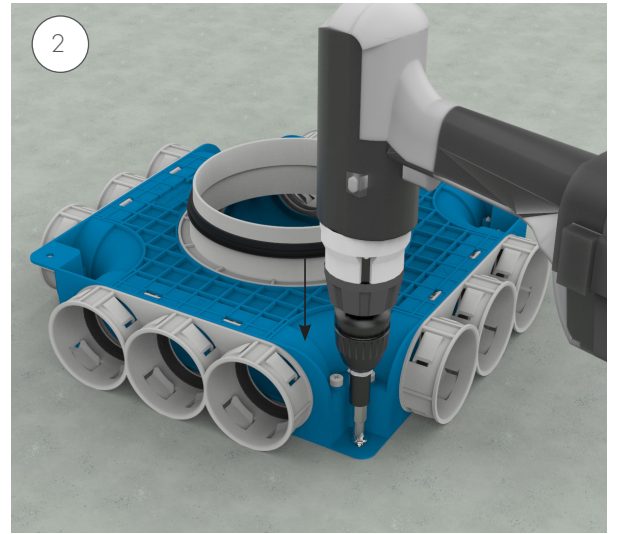

Ø160

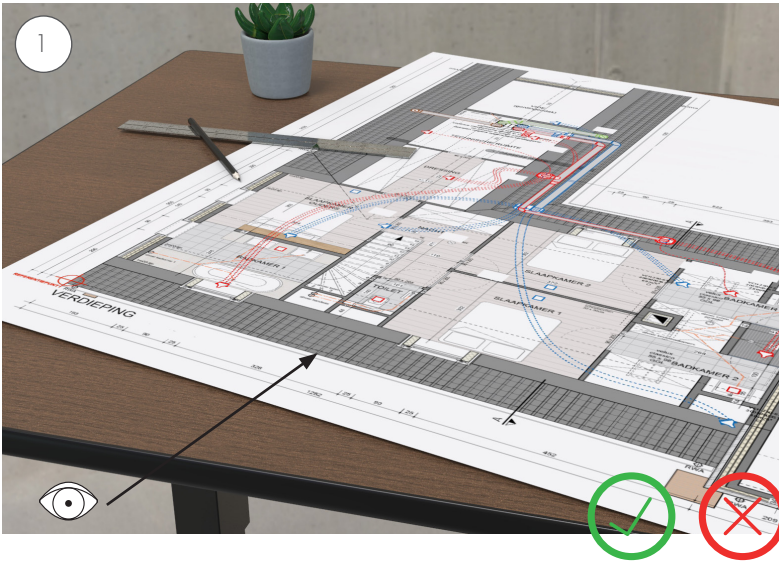
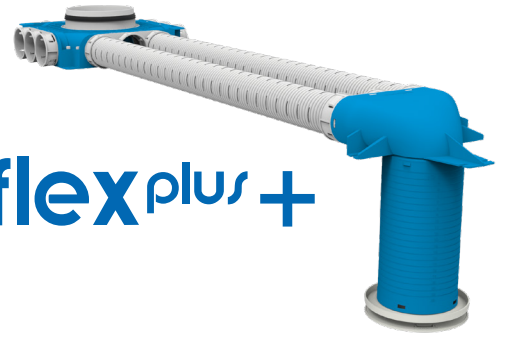
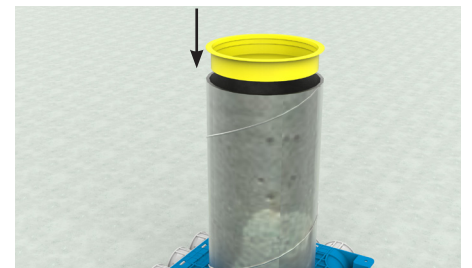
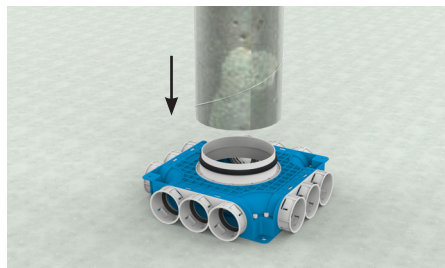
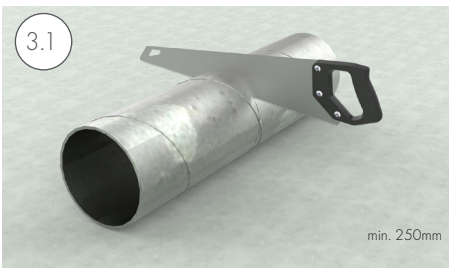

Ø125 / Ø180

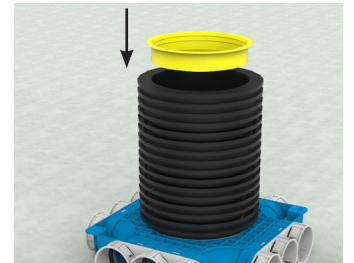
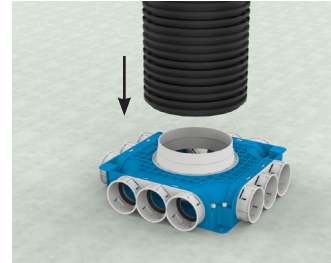
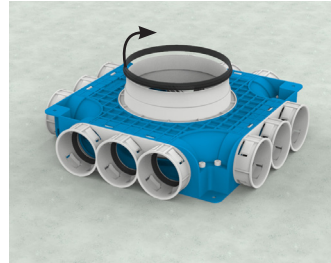
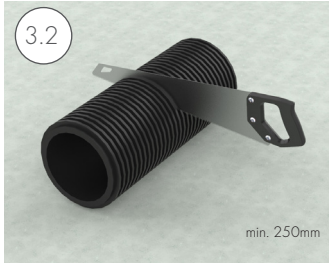

Ø160

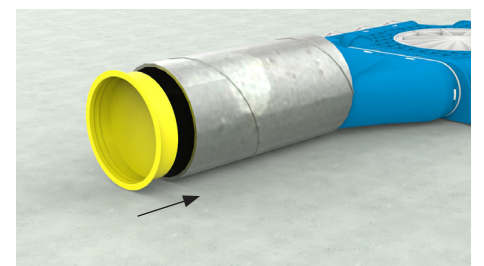
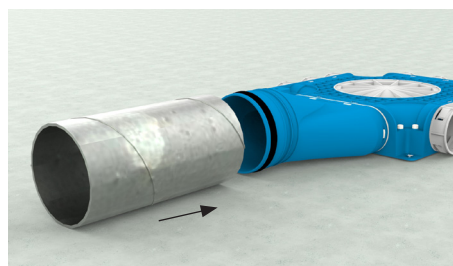
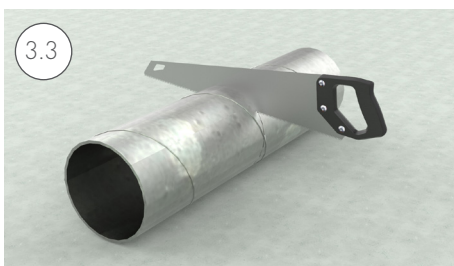

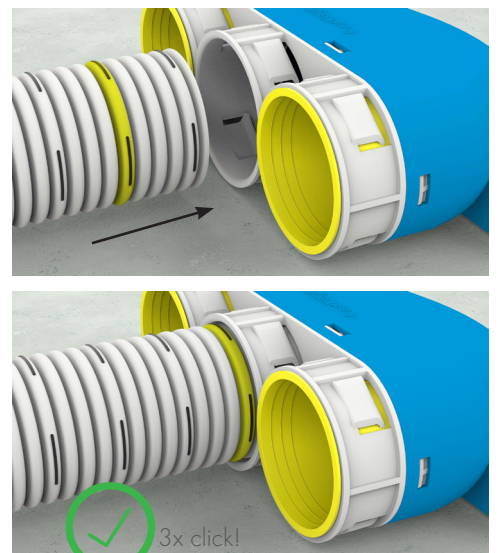
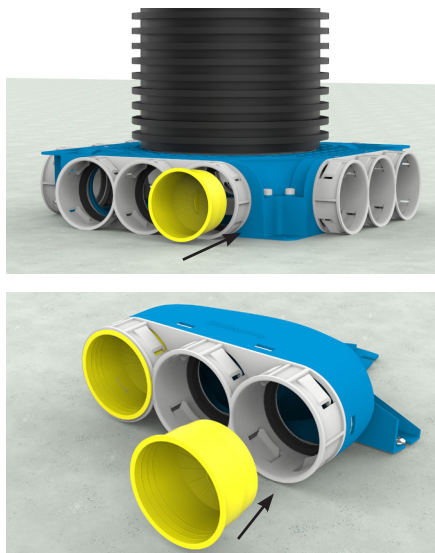
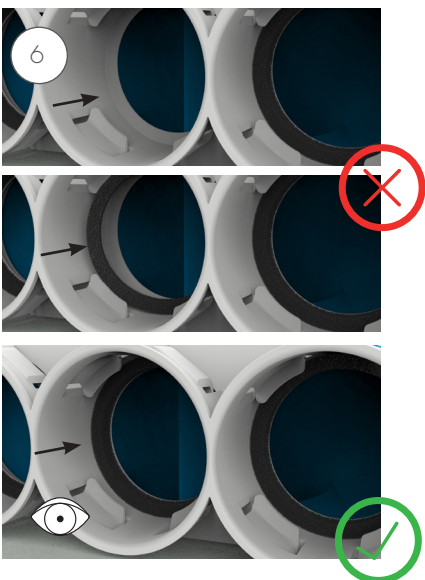
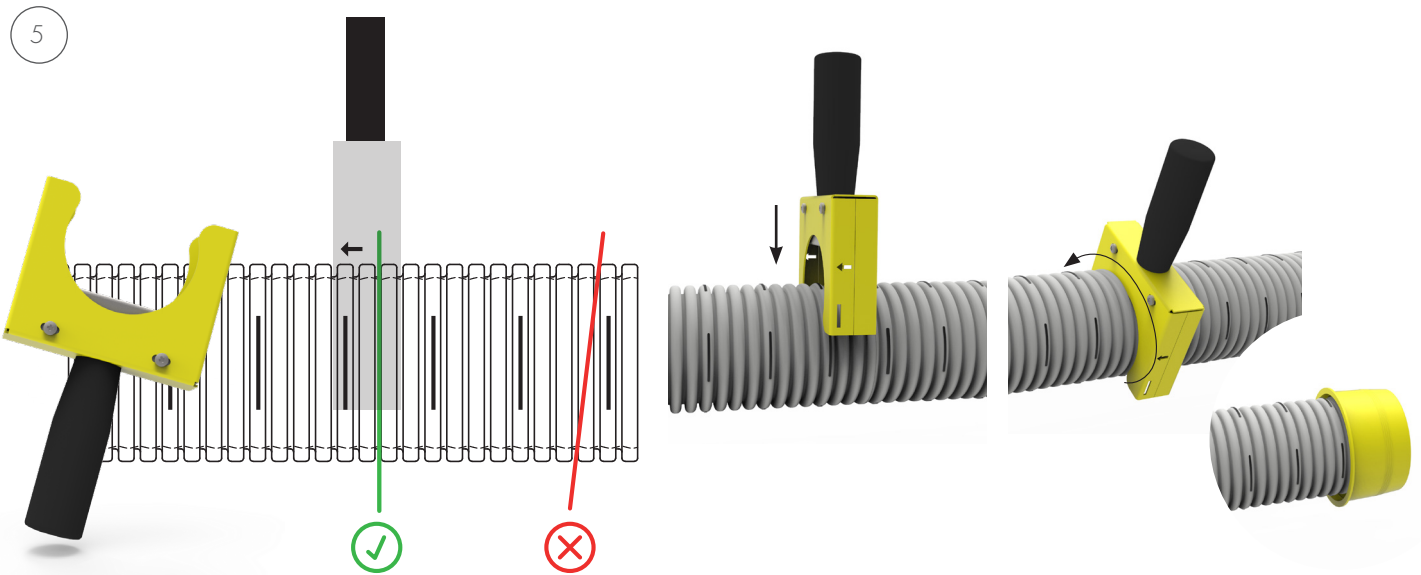
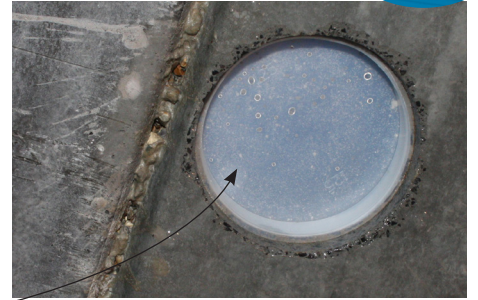
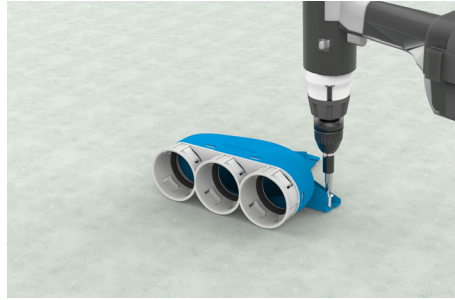
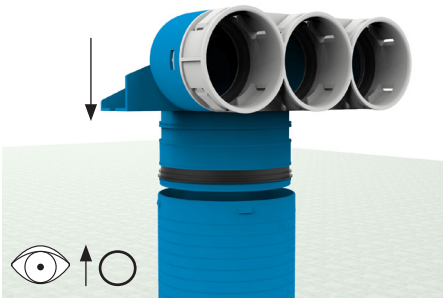
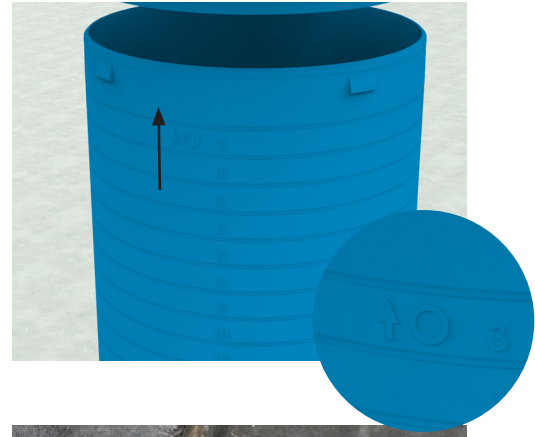
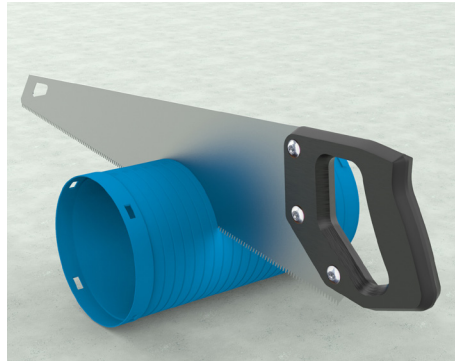
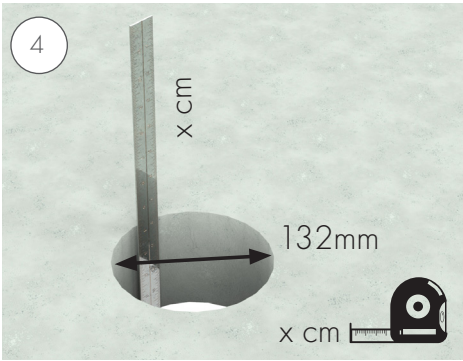

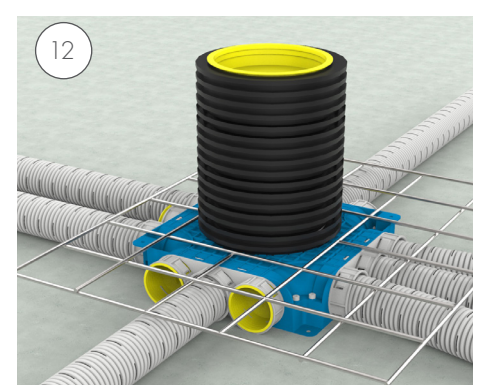
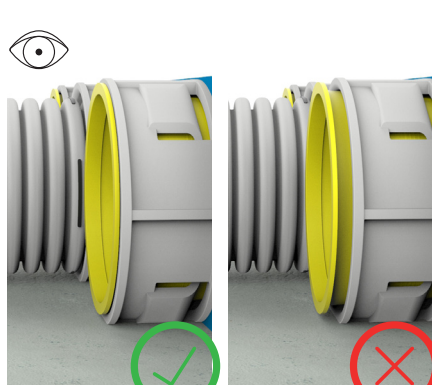
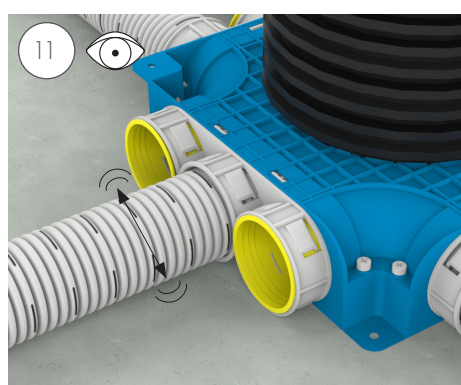
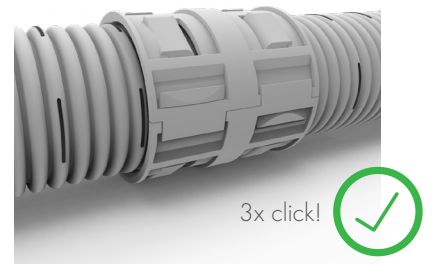
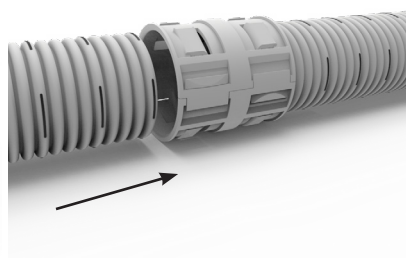
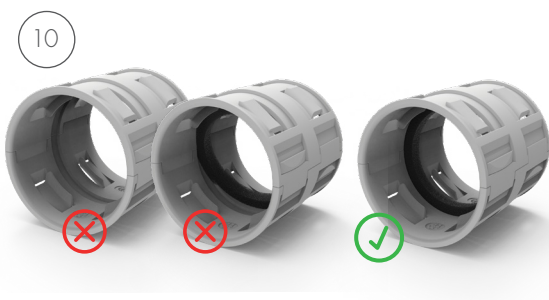
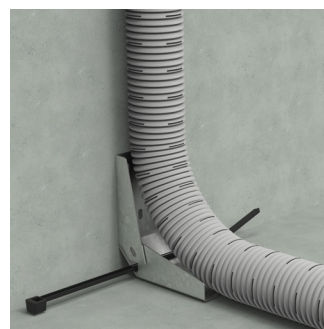
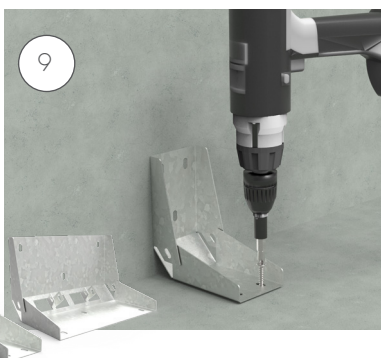
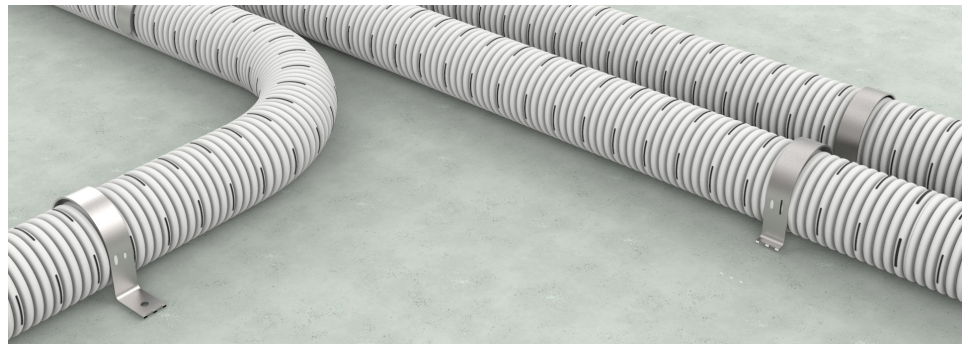
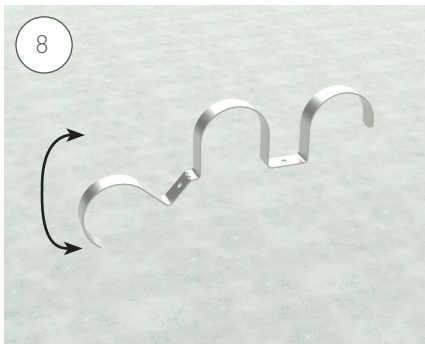
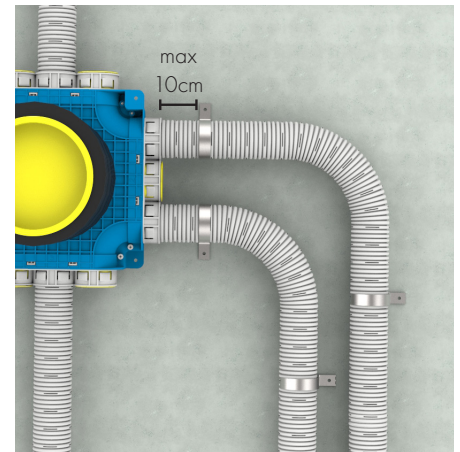
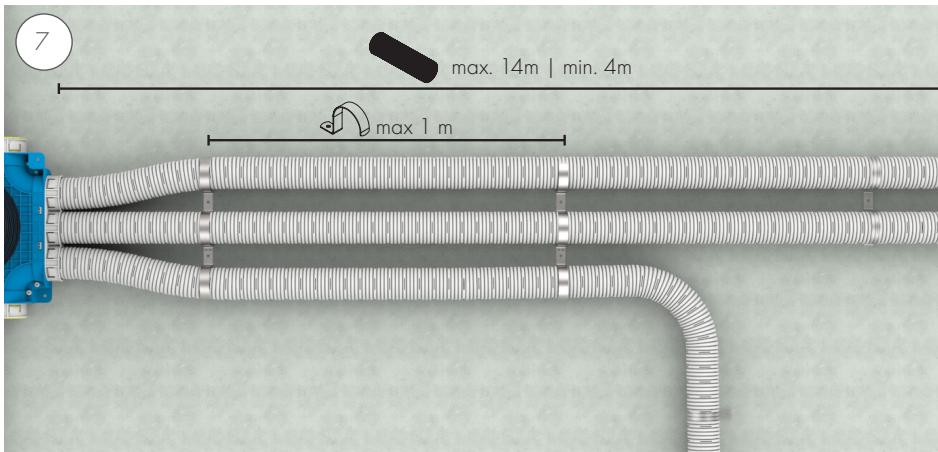



EN This system contains an approved biocide (silver ions encapsulated in a ceramic material – Sanitized MBE99-58 / Bactiglas AM91874) to minimize bacterial formation;  
 NL Dit systeem bevat een goedgekeurd biocide (Zilverionen ingekapseld in keramisch materiaal - Sanitized MBE99-58 / Bactiglas AM91874) om bacterievorming tot een minimum te beperken;  
 DE Dieses System enthält ein zugelassenes Biozid (Silberionen in einem Keramikmaterial eingekapselt - Sanitized MBE99-58 / Bactiglas AM91874), um die Bildung von Bakterien

zu minimieren;  
 FR Ce système contient un biocide approuvé (ions d'argent encapsulés dans un matériau céramique – Sanitized MBE99-58 / Bactiglas AM91874) pour minimiser la formation de bactéries;  
 DK Dette system indeholder et godkendt biocid (selvioner indkapslet i keramisk materiale - Sanitized MBE99-58 / Bactiglas AM91874) for at minimere bakteriedannelse;  
 PL System ten zawiera zatwierdzony środek biobójczy (jony srebra zamknięte w materiale

ceramicznym - Sanitized MBE99-58 / Bactiglas AM91874) w celu zminimalizowania rozwoju bakterii;  
 IT Questo sistema contiene un biocida approvato (ioni d'argento incapsulati in un materiale ceramico - Sanitized MBE99-58 / Bactiglas AM91874) per ridurre al minimo la formazione di batteri.

I.a.w. Biocidal Products Regulation (EU 528/2012)